

TIANJIN K.R.S VALVES CO., LTD.

LEAD VALVE SCIENCE AND
TECHNOLOGY 引领阀门科技

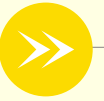

止回阀系列 Check Valves Series



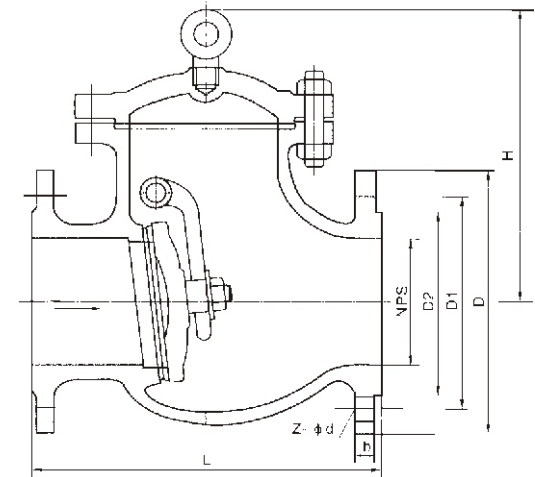
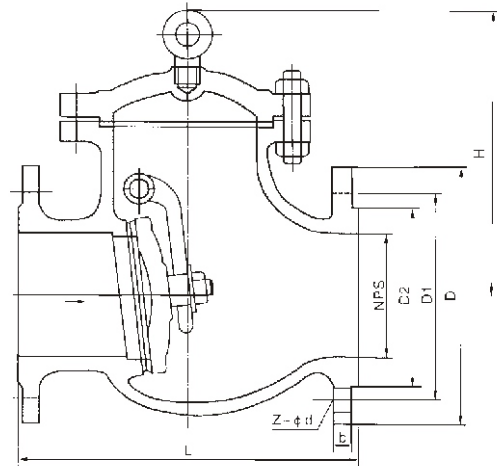

产品执行标准 Production enforce standard

类型TYPE	设计与制造 Desing And Manufacture	结构长度 Face to Face/ End to end	法兰尺寸 Flange Dimension	压力~温度 Pressure Temperature Lating	试验~检验 Inspection and test
旋启式止回阀Swing Check valve	ANSIB16.34	ANSIB16.10	ANSIB16.15	ANSIB16.34	API598
升降式止回阀Lift Check valve	BS1868				

产品性能规范 Chief peoperty and spefication

公称压力(Lb)Nominal Pressore		150	300	600	900
强度试验 Shell test	Mpa	3.1	7.8	15.3	23.1
	Lbf/in ²	450	1125	2225	3350
水密封试验 Water seal test	Mpa	2.2	5.6	11.2	16.8
	Lbf/in ²	315	815	1630	2440
气密封试验 Air seal test	Mpa	0.5~0.7			
	Lbf/in ²	60~100			

主要零件材料及性能 Main part materials property

体、盖、瓣、摇杆、导向套 Body Cover DiskHingeside way bush	销轴 Hinge pin	垫片 Sealing shim	密封面 Sealing Face	工作温度 (°C) Working temperature	适用介质 Suitable medium
WCB	2Cr13	增强柔性石墨 1Cr13/柔性石墨 不锈钢耐酸石棉 PTFE 齿型垫片 Enhanced Flexible graphite 1Cr13/Flexible Graphite S.S/Acie-proof asbestos Tooth profile gashker	13Cr STL 本体材料 PTFE 尼龙 With bodymater rial Nylon	≤425	水、蒸汽、油品、 硝酸类、醋酸类、 强氧化介质、 尿素 Water steam Petroleum products Nitric acid Acetic acid
WC1				≤450	
WC6				≤540	
WC9				≤570	
C5 C12				≤550	
CF8				304	
CF3	316				
CF8M	304L				
CF3M	316L				

主要外形和连接尺寸 Main external and connection dimension

单位Unit: mm

NPS	DN	Class 150Lb/300Lb/600Lb							WT (Kg)
		L	D	D1	D2	b	Z-φd	H	
2"	50	203	157	120.7	92	19.50	4-φ19	161	17
2 1/2"	65	216	178	139.7	105	22.5	4-φ19	180	23
3"	80	241	190.5	152.4	127	24	4-φ19	190	33
4"	100	292	229	190.50	157.2	24	8-φ19	220	44
6"	150	356	279	241.5	216	25.5	8-φ22.5	257	78
8"	200	495	343	298.5	270	29	8-φ22.5	292	137
10"	250	622	406	362	324	30.5	12-φ25	350	207
12"	300	698	483	432	381	32	12-φ25	398	279
14"	350	787	533	476.8	413	35	12-φ29	445	387
16"	400	864	597	539.8	470	37	16-φ29	490	446
18"	450	978	635	577.8	533	40	16-φ32	520	621
20"	500	978	698	635	584	43	20-φ32	546	770
24"	600	1295	813	749.3	692	48	20-φ35	880	970
2"	50	267	165	127	92	22.5	8-φ19	179.5	20
2 1/2"	65	292	190	150	105	25	8-φ22	190	24
3"	80	318	210	168	127	29.0	8-φ22.5	212.4	40
4"	100	356	254	200	157	32.0	8-φ22.5	246	51
6"	150	445	317.5	269.7	216	37.0	12-φ22.5	292	90
8"	200	533	381	330	270	41.5	12-φ25.5	328	175
10"	250	622	444.5	387	324	48.0	16-φ28.5	378.6	210
12"	300	711	521	451	381	51.0	16-φ32	420	286
14"	350	838	584	514	54	54	20-φ32	470	400
16"	400	864	648	572	57	57	20-φ35	530	550
18"	450	978	711	629	60	60	24-φ35	584	700
20"	500	1016	775	686	64	64	24-φ35	610	860
24"	600	1346	914	813	70	70	24-φ41	860	1931
2"	50	292	165	127	92	25	8-φ19	203	34
2 1/2"	65	330	190	150	105	29	8-φ22	229	45
3"	80	356	210	168	127	32	8-φ22	235	63
4"	100	432	273	216	157	38	8-φ25	286	114
6"	150	559	356	292	216	48	8-φ29	330	207
8"	200	660	419	349	270	56	12-φ29	381	387
10"	250	787	508	432	324	64	12-φ32	457	580
12"	300	838	559	489	381	67	16-φ35	584	778
14"	350	889	603	527	413	70	20-φ38	635	9869
16"	400	991	686	603	470	76	20-φ41	684	1380

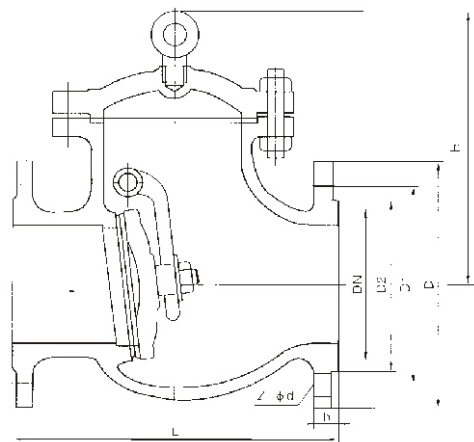

主要外形和连接尺寸 Main external and connection dimension

单位Unit: mm

公称 口径 DN	主要外形尺寸和连接尺寸 (mm) Main external and connecting dimensions							WT (Kg)
	L	D	D1	D2	b	Z-φd	H	
H44H-16C H44W-16C H44W-16P H44W-16R H44W-16I								
50	230	160	125	100	16	4-φ18	135	21
65	290	180	145	120	18	4-φ18	142	28
80	310	195	160	135	20	8-φ18	165	38
100	350	215	180	155	20	8-φ18	180	58
125	400	245	210	185	22	8-φ18	210	92
150	480	280	240	210	24	8-φ23	233	130
200	500	335	295	265	26	12-φ23	304	210
250	550	405	355	320	30	12-φ25	348	294
300	650	460	410	375	30	12-φ25	390	367
350	750	520	470	435	34	16-φ25	430	410
400	850	580	525	485	36	16-φ30	468	461
450	950	640	585	545	40	20-φ30	523	570
500	1025	705	650	608	44	20-φ34	525	850
H44W-25 H44W-25 H44W-25P H44W-25R H44W-25I								
50	230	160	125	100	20	4-φ18	160	22
65	290	180	145	120	22	8-φ18	175	29
80	310	195	160	135	22	8-φ18	185	38
100	350	230	190	160	24	8-φ23	220	61
125	400	270	220	188	28	8-φ25	248	96
150	480	300	250	218	30	8-φ25	276	132
200	550	360	310	278	34	12-φ25	350	213
250	650	425	370	332	36	12-φ30	410	297
300	750	485	430	390	40	16-φ30	430	372
350	850	550	490	448	44	16-φ34	518	415
400	950	610	550	505	48	16-φ34	560	480
450	1025	660	600	555	50	20-φ34	582	610
500	1150	730	660	610	52	20-φ41	618	920

主要外形和连接尺寸 Main external and connection dimension

单位Unit: mm

公称 口径 DN	主要外形尺寸和连接尺寸 (mm) Main external and connecting dimensions										WT (Kg)
	L	D	D1	D2	D6	b	f	f2	Z-φd	H	
H44H-40 H44W-40 H44W-40P H44W-40R H44W-40I											
50	230	160	125	100	88	20	3	4	4-φ18	169	22
65	290	180	145	120	110	22	3	4	8-φ18	173	29
80	310	195	160	135	121	22	3	4	8-φ18	185	38
100	350	230	190	160	150	24	3	4.5	8-φ23	220	61
125	400	270	220	188	176	28	3	4.5	8-φ25	248	96
150	480	300	250	218	204	30	3	4.5	8-φ25	270	132
200	550	375	320	282	260	38	3	4.5	12-φ30	342	213
250	650	445	385	345	313	42	3	4.5	12-φ34	401	297
300	750	510	450	408	364	46	4	4.5	16-φ34	423	372
350	850	570	510	465	422	52	4	5	16-φ34	455	415
400	950	655	585	535	474	58	4	5	16-φ41	510	480

主要外形和连接尺寸 Main external and connection dimension

单位Unit: mm

公称 口径 DN	主要外形尺寸和连接尺寸 (mm) Main external and connecting dimensions										WT (Kg)
	L	D	D1	D2	D6	b	f	f2	Z-φd	H	
H44H-64 H44W-64 H44W-64P H44W-64R H44W-64I											
50	300	175	135	105	88	26	3	4	4-φ23	177	27
65	340	200	160	130	110	28	3	4	8-φ23	197	37
80	380	210	170	140	121	30	3	4	8-φ23	212	57
100	430	250	200	168	150	32	3	4.5	8-φ25	248	89
125	500	295	240	202	176	36	3	4.5	8-φ30	296	135
150	550	340	280	240	204	38	3	4.5	8-φ34	330	184
200	650	405	345	300	260	44	3	4.5	12-φ34	385	266
250	775	470	400	352	313	48	3	4.5	12-φ41	445	396
300	900	530	460	412	364	54	4	4.5	16-φ41	474	643
350	1025	595	525	475	422	60	4	5	16-φ41	514	815
400	1150	670	585	525	474	66	4	5	16-φ48	616	1234

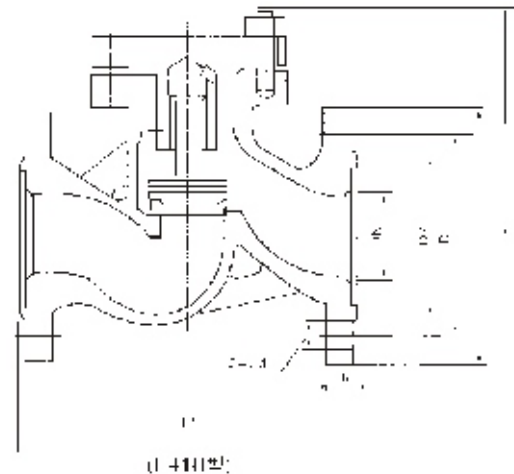

主要外形和连接尺寸 Main external and connection dimension

单位Unit: mm

公称通径 DN	主要外形尺寸和连接尺寸 (mm) Main external and connecting dimensions							WT (Kg)
	L	D	D1	D2	b	Z-φd	H	
H41H-16C H41W-16C H41W-16P H41W-16R H41W-16I								
15	130	95	65	45	14	4-φ14	77	3
20	150	105	75	55	14	4-φ14	77	4
25	160	115	85	65	14	4-φ14	80	5
32	180	135	100	78	16	4-φ18	85	7
40	200	145	110	85	16	4-φ18	95	9
50	230	160	125	100	16	4-φ18	105	10
65	290	180	145	120	18	4-φ18	120	20
80	310	195	160	135	20	8-φ18	130	30
100	350	215	180	155	20	8-φ18	140	39
125	400	245	210	185	22	8-φ18	155	50
150	480	280	240	210	24	8-φ23	180	70
200	600	335	295	265	26	12-φ23	215	161
250	730	405	355	320	30	12-φ25	260	251
300	850	460	410	375	34	12-φ25	315	395
H41H-25 H41W-25 H41W-25P H41W-25R H41W-25I								
15	130	95	65	45	16	4-φ14	100	3.4
20	150	105	75	55	16	4-φ14	105	5
25	160	115	85	65	16	4-φ14	120	5.7
32	180	135	100	78	18	4-φ18	130	9.1
40	200	145	110	85	18	4-φ18	135	11.8
50	230	160	125	100	20	4-φ18	149	14.4
65	290	180	145	120	22	8-φ18	160	23
80	310	195	160	135	22	8-φ18	169	30
100	350	230	190	160	24	8-φ23	194	44
125	400	270	220	180	28	8-φ25	222	65
150	480	300	250	218	30	8-φ25	255	99
200	600	360	310	278	34	12-φ25	305	190
250	730	425	370	332	36	12-φ30	355	315
300	850	485	430	390	40	16-φ30	410	450

主要外形和连接尺寸 Main external and connection dimension

单位Unit: mm

公称通径 DN	主要外形尺寸和连接尺寸 (mm) Main external and connecting dimensions								WT (Kg)
	L	D	D1	D2	D6	b	Z-φd	H	
H41H-40 H41W-40 H41W-40P H41W-40R H41W-40I									
15	130	95	65	45	40	16	4-φ14	100	4
20	150	105	75	55	51	16	4-φ14	105	5.5
25	160	115	85	65	58	16	4-φ14	120	6
32	180	135	100	78	66	18	4-φ18	130	12
40	200	145	110	85	76	18	4-φ18	135	14
50	230	160	125	100	88	20	4-φ18	149	18
65	290	180	145	120	110	22	8-φ18	160	27
80	310	195	160	135	121	22	8-φ18	169	36
100	350	230	190	160	150	24	8-φ23	194	50
125	400	270	220	188	176	28	8-φ25	225	75
150	480	300	250	218	204	30	8-φ25	255	119
200	600	375	320	282	260	38	12-φ30	305	217
250	730	445	385	345	313	42	12-φ34	360	365
300	850	510	450	408	364	46	12-φ34	415	310

主要外形和连接尺寸 Main external and connection dimension

单位Unit: mm

公称通径 DN	主要外形尺寸和连接尺寸 (mm) Main external and connecting dimensions								WT (Kg)
	L	D	D1	D2	D6	b	Z-φd	H	
H41H-64 H41W-64 H41W-64P H41W-64R H41W-64I									
15	210	105	75	55	40	18	4-φ14	100	7
20	230	125	90	68	51	20	4-φ18	110	11
25	230	135	100	78	58	22	4-φ18	125	13
32	260	150	110	82	66	24	4-φ23	140	14
40	260	165	125	95	76	24	4-φ23	168	20
50	300	175	135	105	88	26	4-φ23	170	23
65	340	200	160	130	110	28	8-φ23	188	37
80	380	210	170	140	121	30	8-φ23	205	46
100	430	250	200	168	150	32	8-φ25	230	68
125	500	295	240	202	176	36	8-φ30	230	89
150	550	340	280	240	204	38	8-φ34	265	131
200	650	405	345	300	260	44	12-φ34	310	235

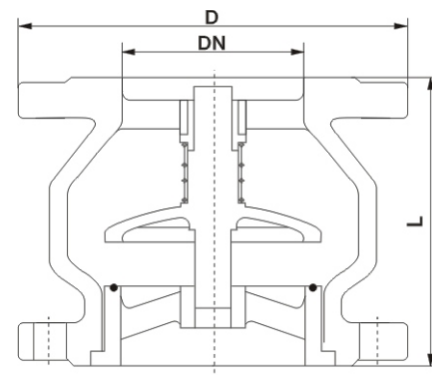

性能规范 Technical data

公称口径 Nominal Diameter(DN)	50-200	
公称压力 PN(MPa) Nominal pressure	16	10
动作压力 Action Pressure	≥0.12MPa	
适用介质 Suitable medium	水 Water	
适用温度°C Suitable temperature	≥100	

主要零部件材料 Material of Main Parts

名称 Name	阀体 Valve body	阀板 valve board	阀杆 Valve pole	导向支架 Guiding holder	缓冲环 Slow a ring down
材料 Matenal	铸铁 Casting	铸铁嵌 Casting Rubber is enclosed	铸青铜 Bronze	铸铁、铜环 Castlron, copper are encircled by	铸铁、铜环 Castlron, copper are encircled by

一可根据用户需求生产铸青铜，不锈钢阀体的止回阀。
One may produce Zhu bronze according to consumer need, stainless steel valve body non-return valve.

外形尺寸及重量 Overall & Connection Dimensions & Wiegh

公称压力 PN(MPa) Nominal pressure	公称口径 DN(mm) Nominal diameter	尺寸 Size (mm)				
		L	D	K	b	Z-φd
1.0	40	124	145	110	18	4-φ18
	50	125	165	125	20	4-φ18
	65	134	185	145	20	4-φ18
	80	153	200	160	22	8-φ18
	100	161	220	180	24	8-φ18
	125	188	250	210	26	8-φ18
	150	220	285	240	26	8-φ18
	200	252	340	295	28	8-φ18
	250	270	395	350	28	12-φ22
	300	286	445	400	28	12-φ22
	350	380	505	460	30	16-φ22
	400	405	565	515	32	16-φ26
	450	430	615	565	32	20-φ26
	500	450	670	620	34	20-φ26
600	510	780	725	36	20-φ26	
1.6	40	124	145	110	18	4-φ18
	50	125	165	125	20	4-φ18
	65	134	185	145	20	4-φ18
	80	153	200	160	22	8-φ18
	100	161	220	180	24	8-φ18
	125	188	250	210	26	8-φ18
	150	220	285	240	26	8-φ18
	200	252	340	295	30	12-φ22
	250	270	405	355	32	12-φ26
	300	286	460	410	32	12-φ26
	350	380	520	470	36	16-φ26
	400	405	580	525	38	16-φ30
	450	430	640	585	40	20-φ30
	500	450	710	650	42	20-φ33
600	510	840	770	48	20-φ36	

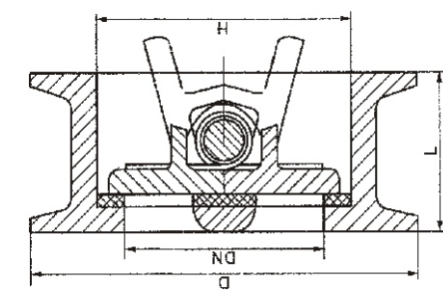

主要外形和连接尺寸 Main External and Connection Dimension

单位Unit:mm

公称口径 DN	PN1.0(MPa)		WT (Kg)	PN1.6(MPa)		WT (Kg)	PN2.5(MPa)		WT (Kg)	PN4.0(MPa)		WT (Kg)
	L	D		L	D		L	D		L	D	
H76H-10C H76W-10P H76W-10R H76H-16C H76W-16P H76W-16R H76H-25 H76W-25P H76W-25R H76H-40 H76Y-40P H76Y-40R												
50	60	109	1.8	60	109	1.8	60	109	2	60	109	2.4
65	67	129	2.6	67	129	2.6	67	129	3.2	67	129	3.8
80	73	144	3.6	73	144	4.2	73	144	4.8	73	144	5.6
100	73	164	4.8	73	170	5.2	73	170	6	73	170	7.5
125	83	194	6.3	83	198	6.7	83	198	9	83	198	11
150	98	220	8.7	98	228	9.4	98	228	12	98	228	15
200	127	275	16.5	127	288	18.7	127	288	22	127	293	27
250	146	330	26.2	146	343	29.4	146	343	38	146	355	48
300	181	380	42.3	181	403	48.5	181	403	54	181	420	78
350	184	440	58	184	460	66	184	460	80	222	480	116
400	198	493	76	198	520	90	198	520	118	232	549	152
450	203	543	98	203	-	130	-	-	-	-	-	-
500	219	598	120	219	-	186	-	-	-	-	-	-
600	222	698	235	222	-	298	-	-	-	-	-	-

主要外形和连接尺寸 Main External and Connection Dimension

H77X-10-40C/P/R 单位Unit:mm

公称口径 DN		D	D1	D2	L	R	t	WT(Kg)
mm	inch							
50	2"	107	65	43.3	43	28.8	19	1.5
65	2.5"	127	80	60.2	46	36.1	20	2.4
80	3"	142	94	66.4	64	43.4	28	3.6
100	4"	162	117	90.8	64	52.8	27	5.7
125	5"	192	145	116.9	70	65.7	30	7.3
150	6"	218	170	144.6	76	78.6	31	9
200	8"	273	224	198.7	89	104.4	33	17
250	10"	328	265	233.7	114	127	50	26
300	12"	378	310	283.9	114	148.3	43	42
350	14"	438	360	332.9	127	172.4	45	55
400	16"	489	410	381.0	140	197.4	52	75
450	18"	539	450	419.9	152	217.8	58	101
		555						107
500	20"	594	505	467.8	152	241	58	111
600	24"	690	624	572.6	178	295.4	73	172
700	28"	800	720	680	229	354	98	219

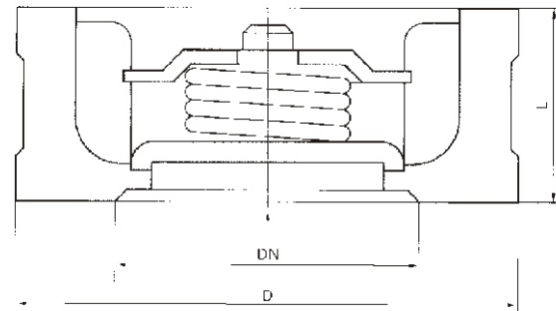

主要外形和连接尺寸 Main External and Connection Dimension

单位Unit:mm

公称通径 DN	L	D			WT(Kg)
		1.6Mpa	2.5Mpa	4.0Mpa	
H71H-16C H71H-25 H71H-40 H71W-16P H71W-25P H71W-40P H71W-16R H71W-25R H71W-40R					
15	25	48	48	48	0.3
20	31.5	58	58	58	0.5
25	35.5	68	68	68	0.8
32	40	80	80	80	1.3
40	45	90	90	90	1.6
50	56	105	105	105	2.3
65	63	125	125	125	3.3
80	71	140	140	140	4.4
100	80	160	165	165	5.6
125	110	190	195	195	9.2
150	125	215	225	225	12.5
200	160	270	285	290	16.5
250	200	330	340	350	20
300	250	385	400	415	27

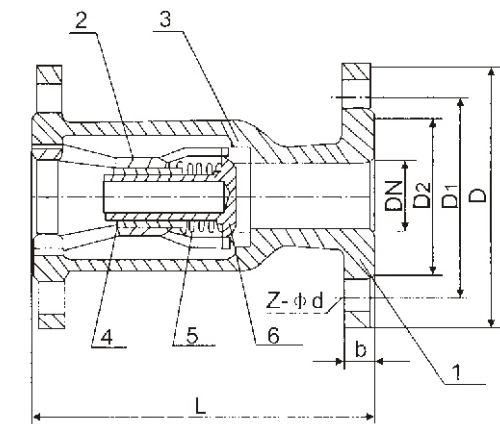

性能规范 Technical Data

产品型号 Type	公称通径 DN(mm) Nominal diameter	性能规范 Technical Data			阀门材质 Valve Material quality		
		公称压力PN(MPa) Nominal Pressure	适用介质 Suitable medium	适用温度(°C) Suitable temperature	阀体 Valve body	阀瓣 Valve clack	密封圈 Sealing washer
H41M-16	15~200	16	水、蒸汽、空气 油品 Water, steam, air and oil	≤250	HT200	1Cr18Ni9Ti 8202	
H41M-25	25~200	25		≤300	WCB		
H41M-25	50~200						

主要外形和连接尺寸 Main external and connection dimension

公称通径 DN	L	D	D1	D2	b	Z-φd
15	130	95	65	45	14	4-14
20	150	105	75	55	16	4-14
25	160	115	85	65	16	4-14
32	180	135	100	78	18	4-18
40	200	145	110	85	18	4-18
50	230	160	125	100	20	4-18
65	290	180	145	120	20	4-18
80	310	195	160	135	22	4-18
100	350	215	180	155	24	8-18
125	400	245	210	185	26	8-18
150	480	280	240	210	28	8-23
200	600	335	295	265	30	12-23

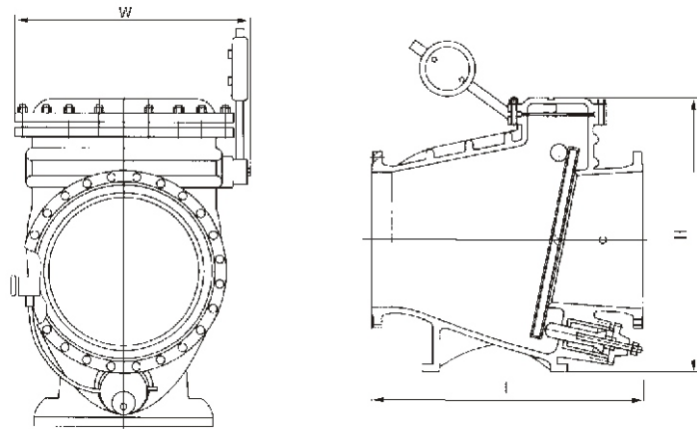

主要外形和连接尺寸 Main External and Connection Dimension

单位Unit:mm

公称通径 DN	主要外形尺寸和连接尺寸 (mm) Main external and connecting dimensions			WT(Kg)
	L	W	H	
HH44T-10 HH44X-10 HH44H-10C HH44T-16 HH44X-16 HH44H-16C HH44T-25 HH44X-25 HH44H-25				
50	230	270	300	58
65	290	290	320	70
80	310	300	354	83
100	350	320	350	120
125	400	340	380	146
150	480	410	500	175
200	500	450	580	205
250	600	550	670	427
300	700	580	730	597
350	800	630	820	800
400	900	700	920	1168
450	1000	800	950	1460
500	1100	900	1100	1795
600	1300	990	1200	2125
700	1400	1120	1550	2668
800	1500	1300	1700	3050

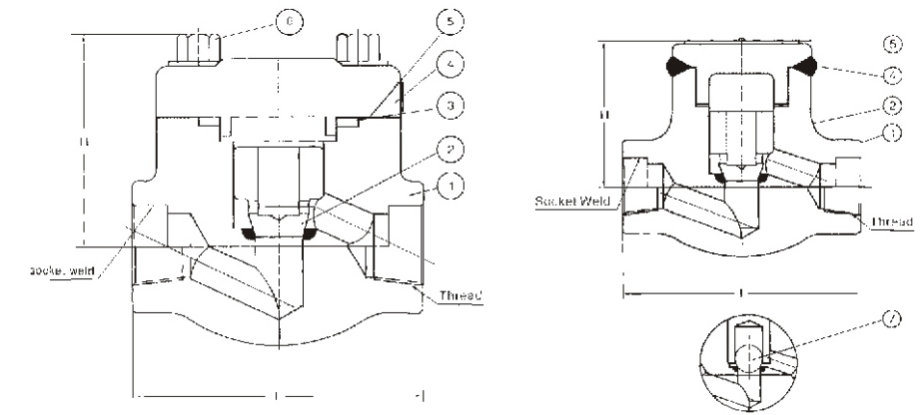

主要外形和连接尺寸 Main External and Connection Dimension

单位Unit:mm

公称通径 DN	主要外形尺寸和连接尺寸 (mm) Main external and connecting dimensions							WT(Kg)	
	L	d	S	L1	T	L2	H	FLD.	SC/SW
H41H-16C H41H-25 H41H-40 H11H-16C H11H-25 H11H-40 H61H-16C H61H-25 H61H-40 H41H-64 H41Y-100 H41Y-160 H11H-64 H11Y-100 H11Y-160 H61H-64 H61Y-100 H61Y-160 H41Y-1800Lb H11Y-800Lb H61Y-800Lb H61Y-800Lb									
15	90	13	22.5	10	1/2	15	61	3.0	1.5
20	100	18	28.5	11	3/4	17	78	4.0	3.0
25	120	23	34.5	12	1	19	84	5.8	3.9
32	140	28	43	14	1 1/4	21	103	8.5	5.6
40	170	36	49	15	1 1/2	21	118	10.1	8.9
50	200	45	61	16	2	25	132	15.6	12.5

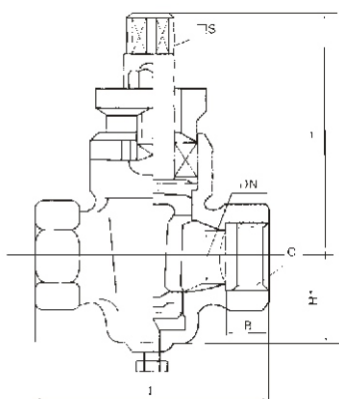
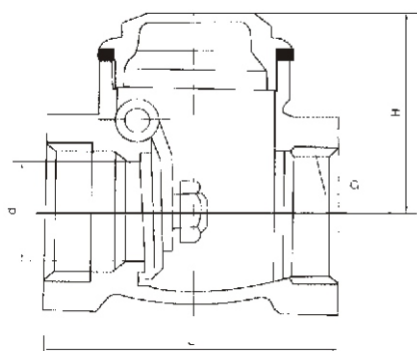

主要外形和连接尺寸 Main External and Connection Dimension

单位Unit:mm

公称通径 DN	G	d	L	H	Cv	WT(Kg)
H14W-16P H14W-16T H14W-25P H14W-25T						
15	1/2"	15	65	44	6.9	0.6
20	3/4"	20	80	53	16.3	0.8
25	1"	25	90	58	30.0	1.5
32	1 1/4"	32	105	62	49.0	2.0
40	1 1/2"	38	120	73	72.0	3.2
50	2"	50	141	78	130	5.0

主要外形和连接尺寸 Main External and Connection Dimension

单位Unit:mm

公称通径 DN	L	G	B	□S	H1	H	WT(Kg)
X13W-10T X13T-10 X13W-10 X13W-10P X13W-10R							
15	85	1/2"	14	11	26	73	0.6
20	90	1"	16	14	34	95	1.0
25	110	1 1/4"	18	17	38	95	1.5
32	130	3/4"	20	19	45	107	2.5
40	150	1 1/2"	22	22	55	157	4
50	170	2"	24	27	74	186	7
65	220	2 1/2"	26	32	82	213	11.5
80	250	3"	30	36	125	202	16.5
100	300	4"	30	46	135	290	22